



REDUCE ELECTROLYTE LOSS TO IMPROVE BATTERY DURABILITY AND SERVICE LIFE

Extended product life cycle supports carbon footprint reduction

The GORE® Catalytic Device capitalizes on Gore's world-leading expertise in porous PTFE and catalytic membrane formation technology.

Designed to be installed inside flooded lead-acid batteries, Gore's small Catalytic Device effectively recombines hydrogen and oxygen, reducing electrolyte loss and extending battery life. This in turn can help to reduce carbon footprint.

Design features

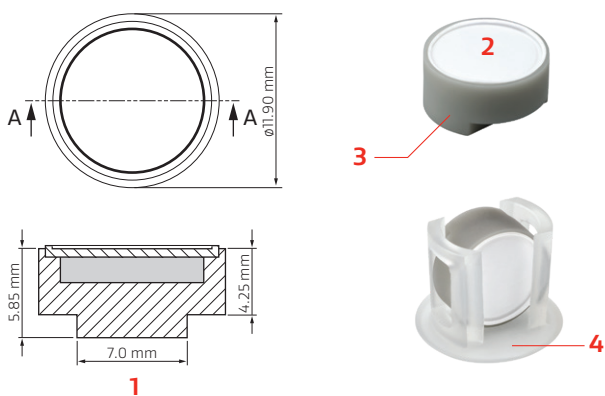

1. Compact, low-profile design
2. Gas-permeable GORE Membrane protects electrolyte
3. Waterproof sheet prevents poisoning and thermal runaway (> 600Ah capacity*)
4. Snap-fit mounting for easy integration

*EN-water loss condition based on limited test data.

Key benefits

Significantly reduces water loss

maintains electrolyte at or below EN-50342-1 W5 level

Extends battery life

by maintaining electrolyte's specific gravity

Supports sustainability

with reduced CO₂ emission from battery manufacturing and recycled lead

Enhances durability

with broad temperature range (-30 °C ~ +75 °C)

How it works

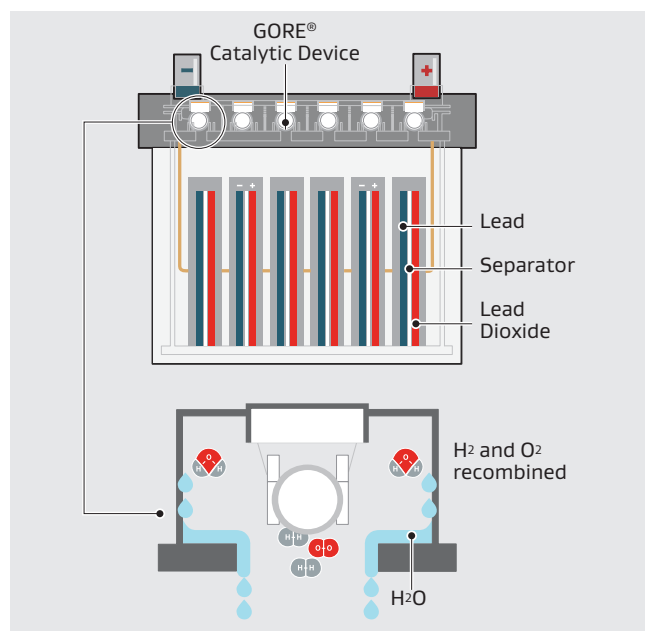

Performance

The GORE® Catalytic Device significantly reduces electrolyte loss, as demonstrated by these 60 °C over-charge and 75 °C discharge-recharge tests.

EN Water Loss Test 60 °C

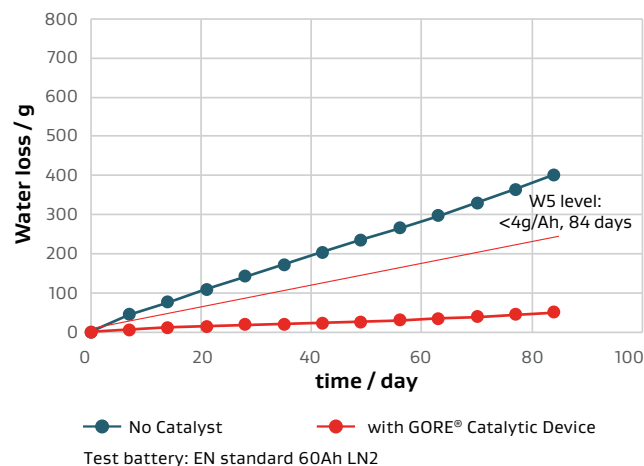

75 °C Cycle Test

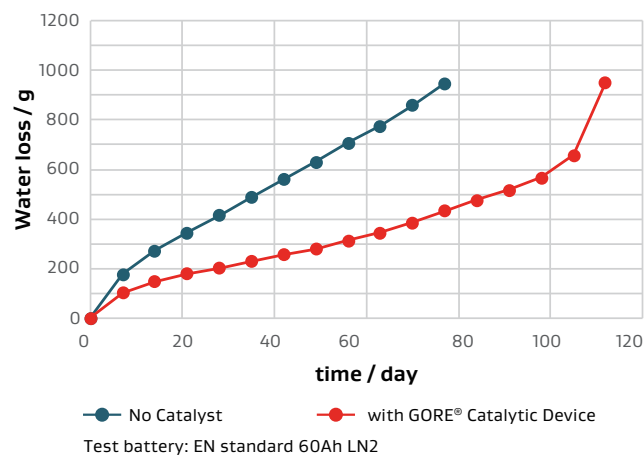

FOR INDUSTRIAL USE ONLY. Not for use in food, drug, cosmetic or medical device manufacturing, processing, or packaging operations.

All technical information and advice given here are based on Gore's previous experiences and/or test results. Gore gives this information to the best of its knowledge, but assumes no legal responsibility. Customers are asked to check the suitability and usability in the specific application, since the performance of the product can only be judged when all necessary operating data are available. The above information is subject to change and is not to be used for specification purposes. Gore's terms and conditions of sale apply to the sale of the products by Gore.

W. L. Gore & Associates, Inc. is certified according to IATF 16949, ISO 9001 and ISO 14001 standards.

GORE, Together, improving life and designs are trademarks of W. L. Gore & Associates. © 2023 W. L. Gore & Associates, Inc.

INTERNATIONAL CONTACTS

Australia +61 2 9473 6800

China +86 21 5172 8299

EMEA +49 89 4612 2211

India +91 22 6768 7000

Japan +81 3 6746 2570

Korea +82 2 393 3411

Mexico +52 81 8288 1281

Singapore +65 6733 2882

South America +55 11 5502 7800

Taiwan +886 2 2173 7799

USA +1 410 506 7812

W. L. Gore & Associates, Inc.

401 Airport Road, Elkton, MD 21922

T +1 800 523 4673 F +1 410 506 8749 E automotive.us@wlgore.com

gore.com/autovents

Product information



Order numbers

For series production

NVA9064

For samples

SMPL-NVA9064

Materials of construction

Housing

Polypropylene

Surface membrane type

Hydrophobic ePTFE

Applications

The GORE® Catalytic Device is designed for use in typical manifold-type automotive lead batteries, including:

- normal/hybrid vehicles
- start-stop vehicles

Gore's Device is also compatible with 6-plug automotive batteries. Contact your local Gore representative for additional details.

Device positioning and installation

The GORE® Catalytic Device is designed to be mounted in a holder or fitting inside the flooded lead battery. Your local Gore representative can provide technical recommendations about holder design as well as device positioning and installation.

