

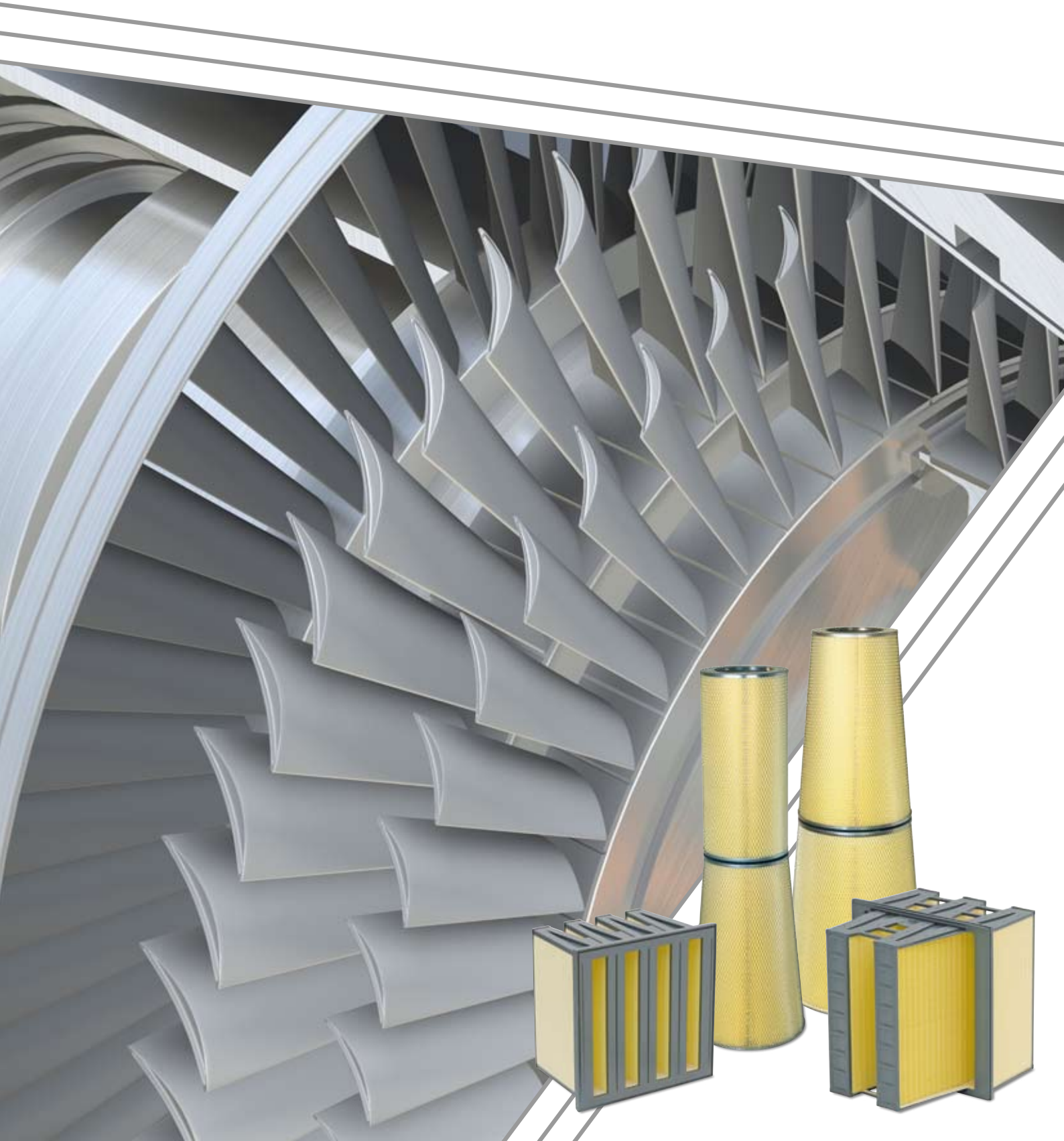

GORE® Turbine Filters

More Power, Less Wear





GORE® Turbine Filters

Increase Power Output by Eliminating Dirt

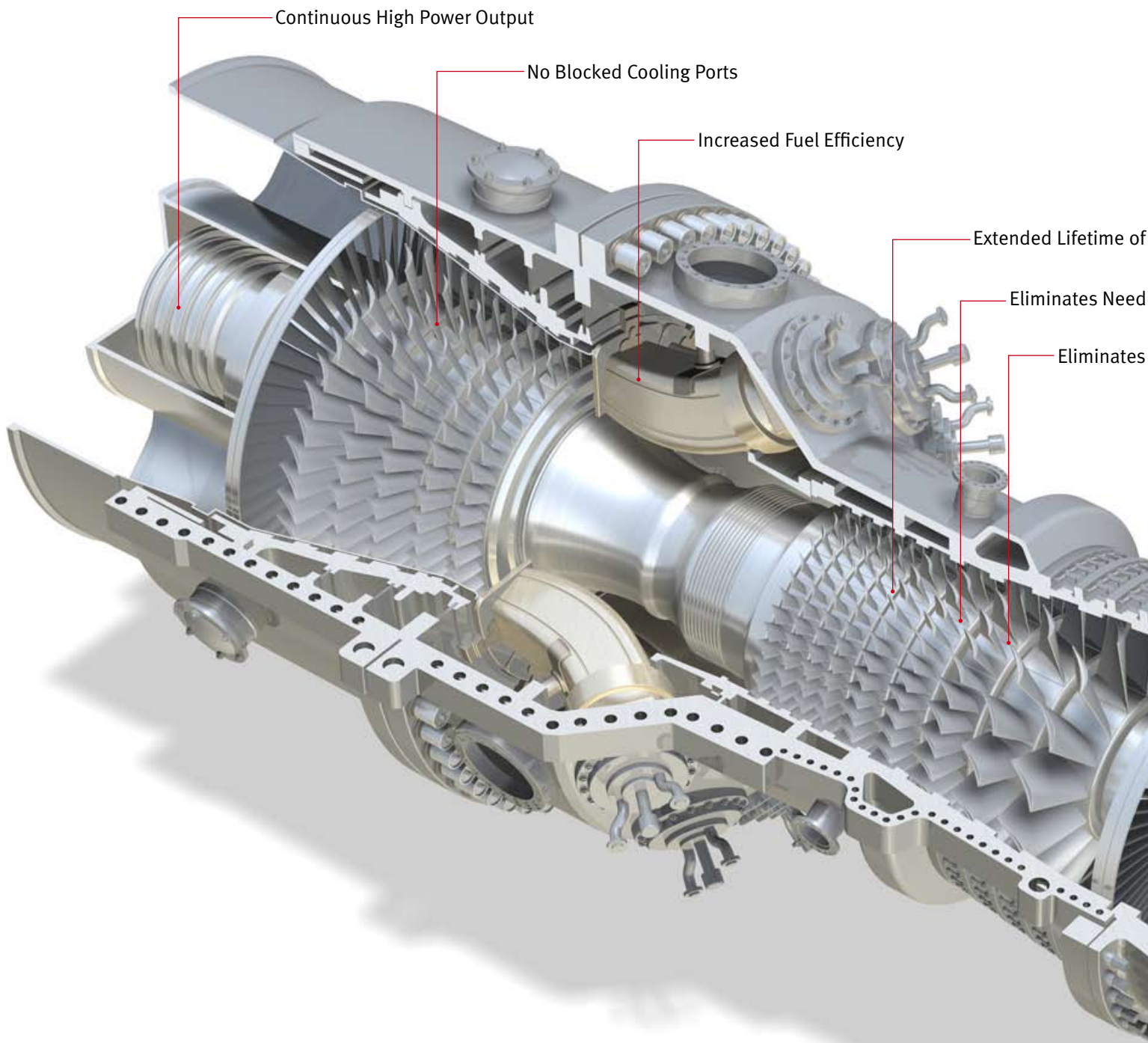

and Other Contaminants from the Turbine

LOWER OPERATING COSTS WHILE MAXIMIZING TURBINE RELIABILITY

More Power

GORE® Turbine Filters optimize power output by eliminating performance reducing deposits in your compressor. Their outstanding H12/E12 filtration efficiency keeps out at least 99.5% of contaminants at the most penetrating particle size (~0.1 µm). This stops power losses while reducing your fuel consumption and associated CO₂ and NO_x emissions. Machine availability and reliability are also significantly increased because there is no need to stop the turbine for off-line compressor washing.

Less Wear

GORE® Turbine Filters significantly reduce your maintenance costs while increasing compressor and turbine lifetimes. Unlike current air intake filters, they capture at least 99.5% of atmospheric particles, and have a unique patented filter media that is waterproof and provides reliable protection from corrosive salts. This reduces unexpected failures and major outages by preventing both fine and corrosive particulates from reaching the engine. GORE® Turbine Filters also directly replace your existing filters with no modifications required to filter housing.

Engine Components

for Compressor Washing

Compressor Fouling

ECONOMIC BENEFITS

- Higher Power Output
- Increased Turbine Availability
- Less Fuel Costs
- Less Maintenance Costs
- No Filter Housing Modifications Required

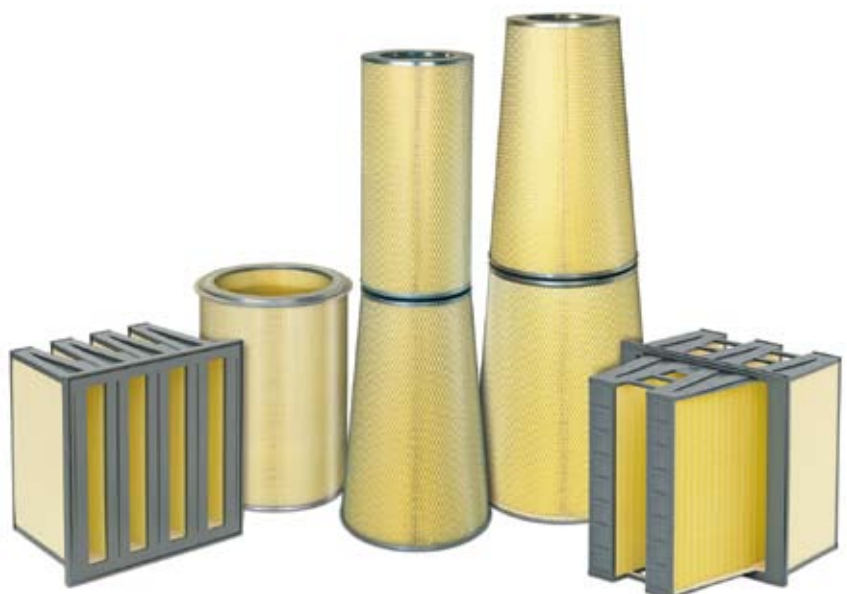



GORE® Turbine Filters

The Difference is Black & White!

Prefilter Layer Removes Bulk of Larger Particles

High Efficiency Membrane Removes Submicron Dust, Water and Salt

High Strength Backer Provides Burst Strength



Actual compressor cleaning fluid after just 1450 hours use of conventional F9 filters.



Clean compressor cleaning fluid after 2500 hours use of GORE® Turbine Filters.

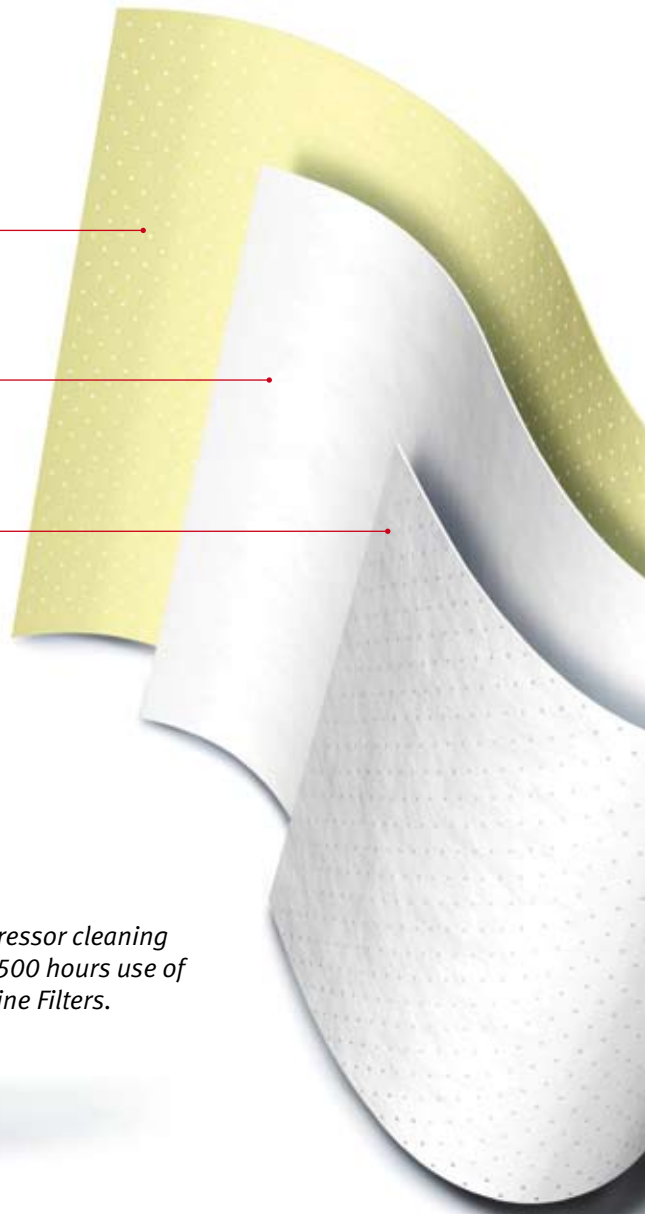

Impact of Filtration Efficiency

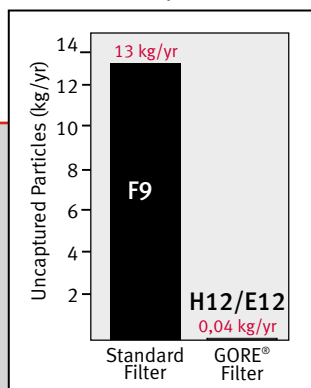

0.04 Kilogram vs. 13 Kilograms Per Year
In a 25 MW turbine with approximately 8200 hours run time per year fitted with F9 filters, almost 13 kg of atmospheric contaminants pass through the filters. Fitted with GORE® Turbine Filters, the amount of unaptured contaminants is only 0.04 kg per year!

A Black & White Difference
Unit 1 – Compressor cleaning fluid after 1450 hours of operation with standard filter.
Unit 2 – Compressor cleaning fluid after 2502 hours using GORE® Turbine Filters.

More Power, Less Wear

Patented 3-Layer Construction Provides H12/E12 Filtration Efficiency at Low Pressure Drops



While conventional filter media show poor efficiency at small particle sizes, unique GORE™ H12/E12 media provides at least 99.5 % efficiency at most penetrating particle size.

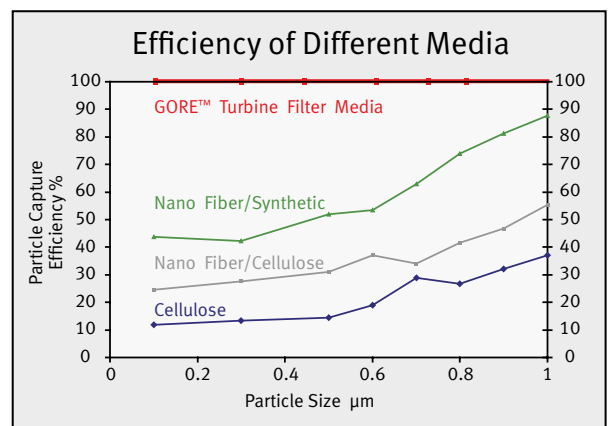

Protection from Salt & Water

SEM showing salt penetration on clean side of F9 filter



SEM showing no salt on clean side of GORE® Turbine Filters

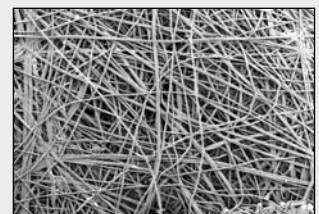

Waterproof GORE™ filter media captures salt particles and dissolved salt preventing downstream contamination such as hot gas corrosion.



GORE® Turbine Filters

Applications Experience

CHP Plant – Heavy Dust and Diesel Fume Value: Eliminated Power Loss and Turbine Erosion

A power plant was situated on a river estuary, adjacent to a bulk coal terminal and railway line. The wind picked up the fine coal dust and diesel fumes and blew straight into the filter housing. The turbine had to be shut down monthly to perform off-line compressor cleaning. Following installation of GORE® Turbine Filters the machine could be left running at maximum performance without any shutdowns for off-line cleaning. Despite the high dust and fog environment the GORE® Turbine Filters achieved a similar lifetime as the previously installed F9 filters.

Cogeneration Power Plant Value: Eliminated Power Loss and Cleaning Shutdowns

A power supplier experienced significant power loss due to compressor fouling on their 250 MW turbine. Using conventional F9 filters the power output was observed to degrade by more than 3% within a few months. In November 2009 the turbine was shut down and underwent a thorough off-line compressor wash. The intake filters were exchanged with GORE® Turbine Filters. Since then the power output is holding steady at the maximum level. No compressor washings have been required, when previously four cycles were carried out per year.

30 MW Turbine	Cleaning Interval
Standard Filters	Monthly
GORE® Turbine Filters	Eliminated

250 MW Turbine	Power Loss
Standard Filters	3%
GORE® Turbine Filters	0

Eliminates Shut Down for Off-line Cleaning



Clean intake after 7600 hours runtime with GORE® Turbine Filters without off-line washings.

Eliminates Power Loss Due to Fouling

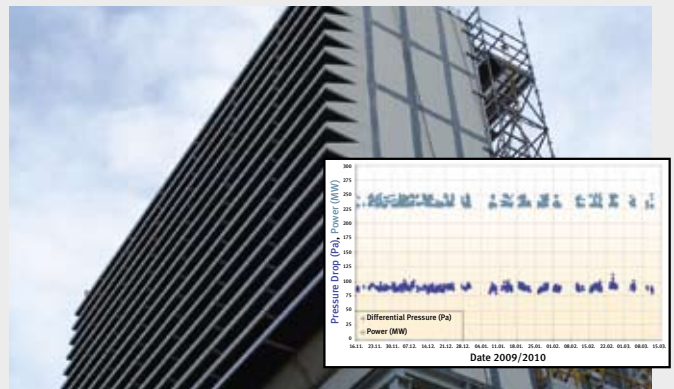

No power loss but steady output level since air intake filters have been replaced with GORE® Turbine Filters.

Technical Information

High Efficiency Filtration (HEPA/EPA) Without Filter House Modification

Turbine operators can now benefit from superior HEPA/EPA filtration without the need to modify the filter house. While other HEPA/EPA solutions require multiple filter stages and more filters in parallel to achieve an acceptable life of the fine filter, GORE® Turbine Filters provide both high filtration efficiency (H12/E12 according to EN 1822) and low pressure drop without additional prefiltration stages. This enables a direct replacement of existing filters with no modifications required to filter housing. GORE® Turbine Filters are also available in various standard dimensions.

Highest Efficiency at Lowest Pressure Drop
(Z-Panel – 600 mm)

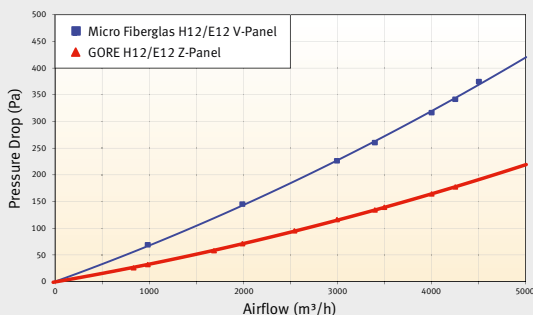
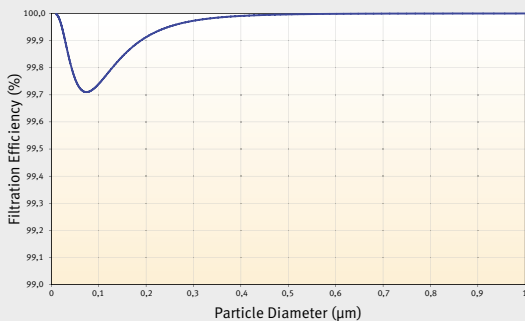

Company Background

W. L. Gore & Associates – A Company Dedicated to Innovation

Best known for products like GORE-TEX® Fabric and GORE-TEX® Medical Devices, Gore is a leading manufacturer of thousands of advanced technology products for the electronics, industrial, fabrics and medical markets. The company is headquartered in Newark, Delaware, and employs approximately 9,000 associates in 30 countries throughout the world including Asia Pacific, Australia, Europe, North and South America.

Since its inception in 1958, Gore has advanced the science of fluoropolymer technology. In 1971 Bob Gore invented expanded Polytetrafluoroethylene (ePTFE) launching hundreds of new products and three new divisions. Gore has repeatedly been named among the “100 Best Companies to Work For”, and our culture is a model for contemporary organizations seeking growth by unleashing creativity and fostering teamwork.





GORE® Turbine Filters



Worldwide Sales and Support

Contact Information

Americas

W. L. Gore & Associates, Inc.
101 Lewisville Road
Elkton, MD 21921
USA
Phone: +1 410 506 3300
Fax: +1 410 506 3494

Europe

W. L. Gore & Associates GmbH
Wernher-von-Braun-Strasse 18
D-85640 Putzbrunn
Germany
Phone: +49 89 4612-2211
Fax: +49 89 4612-2302

Middle East

W. L. Gore & Associates GmbH Middle East
P.O. Box 11 44 70
Abu Dhabi
UAE
Phone: +971 2 4437749
Fax: +971 2 4437748

FOR INDUSTRIAL USE ONLY.

Not for use in food, drug, cosmetic or medical device manufacturing, processing, or packaging operations.

W. L. Gore & Associates

101 Lewisville Road, Elkton, MD 21921
Phone: +1 410 506 3300 Fax: +1 410 506 3494
E-mail: turbinefilters@wlgore.com

www.gore.com/turbinefilters

© GORE and designs are trademarks of W. L. Gore & Associates, Inc.
© 2010 W. L. Gore & Associates

