



# Cooling Filters

## Reliable Direct Air Cooling For Electronic Enclosures

### Enabling Cost-Effective Ambient Air Cooling

Introducing the next generation of cooling technology for increasing the reliability of outdoor electronic enclosures: GORE® Cooling Filters with a new, high efficiency membrane. Unlike active cooling systems, GORE® Cooling Filters enable the use of direct air cooling while providing critical contamination protection. This allows you to take full advantage of the natural thermal efficiencies of ambient air while getting the highest thermal and environmental protection, all at a very cost-effective price.

### High Heat Transfer, 99% Filtration Efficiency

Inside Gore's cooling filter is our new ultra performing media that provides nearly 30% more thermal cooling than previous membrane filters or will last 20% longer. The new media is based on membrane technology pioneered by Gore in 1973 and is the first surface filtration solution of its kind. It is very durable and stops water and corrosive agents from passing through, yet remains highly permeable to air. With a 99% particle filtration efficiency at the 0.3µm level (1cm/sec), the microporous membrane allows cool, clean air to flow into the cabinet while screening out harmful contaminants. In addition, its significantly lower pressure drop results in much higher airflows per footprint and lower energy costs.

### Significantly Reduce Capital and Operating Costs

GORE® Cooling Filters directly replace heat exchangers (HEX) or air conditioning, vastly reducing both capital and operating expenses. They can also be used in conjunction with AC systems to help reduce operational costs. Because they use ambient air, have fewer parts, and a better capacity to hold dust, GORE® Cooling Filters significantly improve Mean Time Between Failures (MTBF) resulting in lower operating cost plus higher network uptime. As of 2008, over 200,000 base stations worldwide depend upon GORE® Cooling Filters for maintenance-free cooling performance.

### Global Deployment in Extreme Conditions

Our deployments span the globe, and have proven successful under extreme ambient operating conditions, including: salt air, wind-driven rain, and heavy industrial pollution. Gore also provides filter/fan designs and custom filters in both low weight composite or rigid aluminum frames. GORE® Cooling Filters provide the most operationally efficient cooling solution for your mechatronic configuration.



### Key Features

- Hydrophobic Membrane
- 99% Filtration Efficiency (@ 0.3µm)
- High Airflow Rates
- No Thermal Transfer Loss
- Works Under All Ambient Conditions
- Protects Against Salt, Corrosive Particles

### Benefits vs. HEX & AC

- High Reliability
- Lower Capital Cost
- Lower Operating Cost
- Less Power Consumption
- Fewer Replacement Parts
- Less Maintenance
- Less Space
- Less Noise

### Applications Include:

- Base Stations
- Backup Power Systems
- Switching Systems



# Cooling Filters

## Construction Materials

Frame	Aluminum
Filter Media	Microporous expanded Polytetrafluoroethylene (ePTFE) membrane with non-woven support
Potting	Polyurethane
Gaskets (optional)	Closed Cell Polyurethane

## Application Performance

Temperature Range	-40°C to +65°C
Humidity	0 to 100 % RH
Typical Initial dP	50 – 100 Pa
Typical Final dP	200 – 250 Pa
Typical Filter Lifetime	3 – 5 Years
Filter Efficiency	99% @ 0.3µm 1 cm/sec

## Industry Compliance

Water & Dust:	IEC 60529 (IP 55 & 65) NEMA 3R
Telecom Standards:	ETSI 300 019 (1-4) Telcordia GR-487 Sec.3.28 Water & Dust Intrusion Sec.3.29 Acoustical Noise Suppression Sec.3.34 Corrosion Resistance
IEC 60950	Airfilters 4.7.35
Underwriters Laboratories:	UL 900 Standard Air Filter Units Class 1
Gore Standards:	Watertight Tested

The optimal performance of any Gore product is dependent upon how it is incorporated into the final device. Please contact a technical sales associate at Gore for applications assistance.

**FOR INDUSTRIAL USE ONLY. Not for use in food, drug, cosmetic or medical device manufacturing, processing, or packaging operations.**

GORE and design are trademarks of W. L. Gore and Associates  
©2011 W. L. Gore & Associates

## W. L. Gore & Associates

UNITED STATES  
W. L. Gore & Associates, Inc.  
101 Lewisville Road  
Elkton, MD 21922  
Phone: +1 410 392 3300  
Fax: +1 410 398 6624

BRASIL  
W. L. Gore & Associates do Brasil Ltda.  
Av. Nações Unidas, 11541 -Cj.52  
São Paulo-SP CEP: 04578-000  
Phone: +55 11 5502 7800  
Fax: +55 11 5502 7801

CHINA  
W. L. Gore & Associates (China), Ltd.  
43F United Plaza  
1468 Nanjing Road West  
Shanghai 200040  
Phone: +86 21 51728299  
Fax: +86 21 6247 9199

KOREA  
W. L. Gore & Associates (Korea), Ltd.  
12F Chongkeundang Bldg  
368 Chungjungro 3 Ga  
Seodaemun Gu, Seoul 120-756  
Phone: +82 2 393 3411  
Fax: +82 2 393 1285

GERMANY  
W. L. Gore & Associates GmbH  
Wernher-von-Braun-Straße 18  
D-85640 Putzbrunn  
Phone: +49 89 4612 2211  
Fax: +49 89 4612 2300

INDIA  
W.L.Gore & Associates(Pacific)Pte.Ltd  
102/103 Matharu Arcade,  
Subhash Road  
Vile Parle(E),Mumbai - 400057, India  
Phone +91 22 6 768 7000  
Fax +91 22 6691 9228

[www.gore.com/coolingfilters](http://www.gore.com/coolingfilters)

## Mounting Options

### Flange Mount

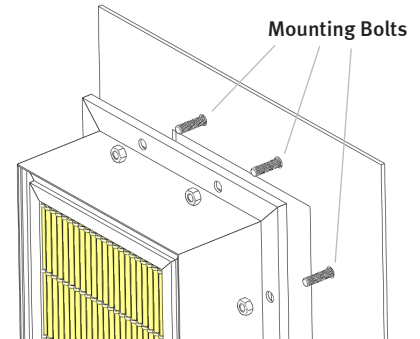

## Frame Sizes

### Aluminum

Length	Width	Depth
150mm to 1000mm	150mm to 750mm	66mm or 104mm

